

## Individual solutions for special-purpose vehicles



-  ELECTRICITY GENERATION
-  COMPRESSED AIR
-  AIR-CONDITIONING TECHNOLOGY
-  TRANSMISSIONS AND SPECIAL CONSTRUCTIONS
-  HYDRAULIC SYSTEMS

# Less means more!

Conventional electricity generators and compressors use their own motors needing their own tank, casing, frame, exhaust system, etc. These heavy components require high maintenance-intensive, lower the payload capacity of your vehicle and occupy a lot of valuable cargo bay. The systematic solutions from Martin KFZ-Technik GmbH offer and provide an enormous saving of space and weight in your service vehicle.



From left: liquor application; chief engineer with the CAD program; CNC department

Since the year 1998, the company Martin KFZ-Technik GmbH is grown to one of the leading companies in the field of bespoke automotive technology and construction of special-purpose vehicles. The company has been founded by general manager Jörg Martin in the small village of Löpsingen.

In the middle of the year 2013, the headquarters in Nördlingen, Fritz-Hopf-Straße 10, were put into operation. For the first time, these headquarters could unite all business operations under one roof. On a plot of 12,500 m<sup>2</sup>, the departments of car-manufacturing, CNC-manufacturing, storage management and administration have been joined together on about 2,700 m<sup>2</sup>. Nowadays, more than 50 employees are working here.

## Overview of our departments:

### ■ Electricity generation

We provide electricity power in the vehicles. With the so-called engine mounting, our systems produce 12 Volt or rather 24 Volt direct current (DC), 230 Volt alternating current (AC) and in the future 400 Volt

three-phase current up to a power of 8 kW. Thanks to a Power-Take-Off (PTO), there is the possibility of up to 35 kW/400 Volt three-phase current for transporters and for bigger trucks up to 100 kW/400 Volt.

### ■ Compressed air

Conceptually, the production of compressed air works similar to the generation of electricity and so we provide compressed air in the customer vehicles of our clients as well. Here, the range goes from a small compressor for service works up to a high performance screw compressor delivering 5 m<sup>3</sup> of production. We can also provide different combinations from electrical and pneumatic/air systems.

### ■ Air-conditioning technology

In cooperation with renowned air conditioning specialists, Martin KFZ-Technik GmbH produces the (necessary) attachment parts and mounting kits systems for special and non-standard air-conditioning compressors necessary in special-purpose vehicles of the airport-apron vehicles, catering and movie set-vehicles, to name but a few. We also provide unique climate con-

trol solutions for the defence industry and their special wishes.

### ■ Transmissions and special constructions

On behalf of some of special vehicle manufacturer's for - special-purpose vehicles, we produce among other things special transmissions in small series. Drawing up the plans, construction, development of the prototypes, line production on our own CNC workstations - our clients & customers find all competences necessary in one company. Particularly our flexibility and our independence are greatly appreciated by our clients.

### ■ Hydraulic systems

We can also implement all our generated power and compressed air solution systems in an existing hydraulic environment.

## Additional services

We're happy to line the interior of your vehicle, fix further mountings, build cable portals or maintain your car during your annual visit to our factory in Nördlingen. Just ask!





# ELECTRICITY POWER GENERATION

## We've got the power!

The mobile generation of electricity power takes the major part of our development work and is the essential base for many producers for special-purpose vehicles to achieve their special fixtures and extensions.

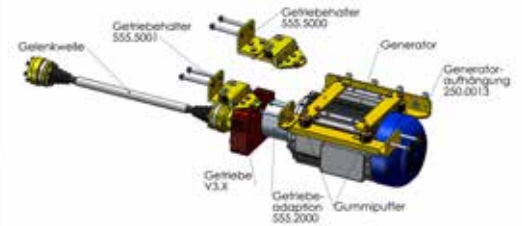

CAD drawing underfloor mounting kit

Over the years we have provided in excess of 500 solutions for various engines and vehicles. We develop mounting sets for common commercial vehicles under consideration of factors such as belt routing and alignment, automatic tensioning devices, ratio and radius of generator free-wheels. Our mounting sets are developed with the aspects of reliability and durability being of uppermost importance. Every set undergoes vigorous reliability, functionality and durability checks e.g. temperature and vibrational behaviour at critical points.

A complete engine generator kit including power electronics, mounting kit and wiring weighs between 25 and 45 kg and can deliver up to 8 kW (single-phase, 230 V). A conventional stand-alone generator with similar performance weighs much more and occupies much more space. The most our systems can be fitted by our customers, dependant on complexity. Our kits are designed with modern CAD systems from our construction department. Technical drawings, exploded view drawings, parts lists and assembly instructions of our standard kits are provided to our customers to enable self-fitting.



certificate of Martin KFZ-Technik



From left: self-conception power distribution box; underfloor generator; underfloor generator with PTO; motor mounting kit

## Advantages of the electricity generator systems

**Payload profit:** we use the existing engine of the vehicle and can thereby register a weight reduction, so you can use the weight reduction for additional loading.

**Economy of space:** our equipment is built into the engine compartment or under the vehicle. That's why the cargo bay remains preserved completely apart from the plug distributor for the purchase of power.

**Low-maintenance:** With the elimination of the extra motor power set, the maintenance is reduced to a minimum.

**Safety at work:** exhaust burns, fuel contact or fuel vapour contact whilst filling can not happen with our systems.

**Environmental friendliness:** The engine of a modern van is much „cleaner“ than that of an industrial generator motor.

**Mobility:** because our generator and air systems are integrated into the vehicle, the trailer hitch isn't needed to transport a generator. This increases mobility in the city where parking space is limited and also means that a standard driving license is sufficient for your employees.



# COMPRESSED AIR

## Give your vehicle lungs!

We have various compressor solutions which are chosen depending on the set-up of the vehicle concerned.

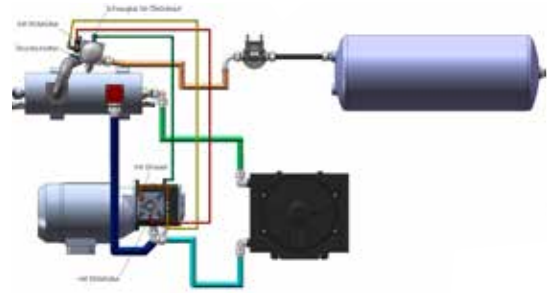

compressed air system

### 1. Drive directly via the PTO

A constant velocity shaft connects the transmission with the PTO. The compressor is connected with the transmission with a claw coupling directly or via an additional drive shaft.



### 2. Driven in series with the underfloor generators

This option utilises an underfloor kit.



### 3. Driven electrically

An underfloor generator provides the necessary power supply. The screw compressor is driven by a conventional electric motor. This option is used when space is very limited. The air delivery ranges from 0.75 m<sup>3</sup>/min to 3.5 m<sup>3</sup>/min at 8 bar, a higher air delivery is possible with HGVs. We use screw compressors from reputable manufacturers, and apart from the control of the screw

compressor, all components (oil separation, oil cooling, control valves, air tank etc.) are mounted underneath the vehicle.

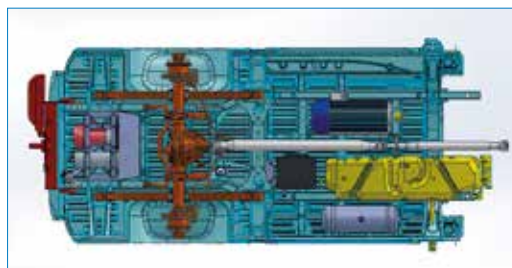

From left: compressed air generator; CAD drawing underfloor; compressor

## Advantages of the underfloor compressed air system

The advantages of our underfloor compressor system are similar to those in our modern power generation systems. Conventional solutions need an extra motor and other necessary components such as tank, housing, exhaust system, battery, starter ... our power source is the vehicle engine which as such adds no weight. We develop and produce a kit which integrates the generator or compressor underneath the vehicle.

By connecting the PTO to the compressor or generator we obtain the same or more delivery of power or air without sacrificing payload or loading space. Combining both systems leads to massive advantages e.g. a 7.5 t breakdown truck with our systems is 500 kg lighter.



## Applications

- + Special cooling systems for refrigerated vehicles
- + Air conditioning systems for vehicles used in climate zone 4
- + Air conditioning systems for tv and radio operation vehicles

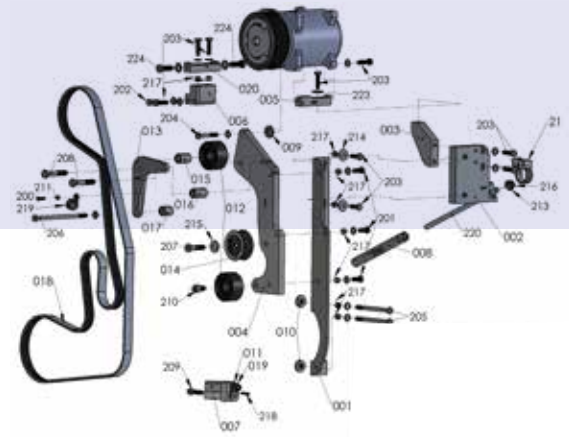

air compressor by motor mounting kit

## AIR CONDITIONING

### Stay cool!

Satellite transmission vehicles accumulate a lot of heat which has to be cooled reliably to protect the sensitive equipment from failure due to overheating.

Our longstanding experience with the design and construction of generator mounting kits enabled us to modify them or make them compatible with additional compressors by means of an adapter. We work very closely with national and international air conditioning manufacturers in this sector too. We are strong in high quantity line production but also small, technically demanding small series.

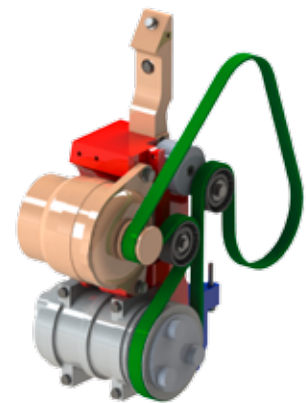

blow-up representation

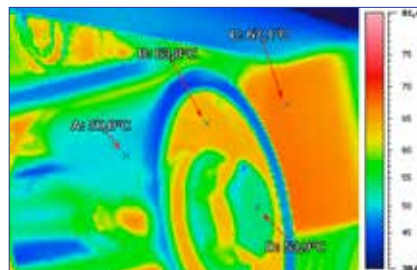

From left: thermal imaging; airport service-trolleys



From left: air compressor in the engine compartment; built custom-made air compressor with motor mounting; air compressor



## ▪ Applications

- + Bespoke transmission systems
- + Customer-specific CNC components in small series or mass production

## ▪ Advantages

- + One-off or series production
- + One contact person for development and production
- + In-house production with our own CNC station

From left: cable trap; custom-made gear; own design exhibition tables



# TRANSMISSIONS AND SPECIAL CONSTRUCTIONS

## Impossible? Not for us!

No enquiry is trivial, we often work with our customers on one-off solutions. Whether one-off or line production - we implement our expertise with every customer.

No enquiry is trivial, we often work with our customers on one-off solutions. Whether one-off or line production - we implement our expertise with every customer.

We equip a Mercedes Benz Vito with a transmission PTO which cannot be purchased ex-work for a well-known high pressure rinsing vehicle manufacturer. An extremely compact vehicle with a high performance interface can dispose of oil spillage in underground car parks and multi-storey car parks, where larger vehicles have to stay outside.

We produce an offset drive for a reputable manufacturer of AWD vehicles, enabling the use of the standard transmission PTO which otherwise would have been blocked by the 4x4 distribution gear.

For a fire engine manufacturer we have developed and produce an intermediate transmission up to 300 kW.

Tell us your problem, we have a solution!

special gearboxes



From left: transmission with underfloor system; development; special gear made



# HYDRAULIC SYSTEMS

## Nothing is more flexible!

Existing hydraulic systems as in crane vehicles for example can often be integrated or upgraded with our systems with ease.

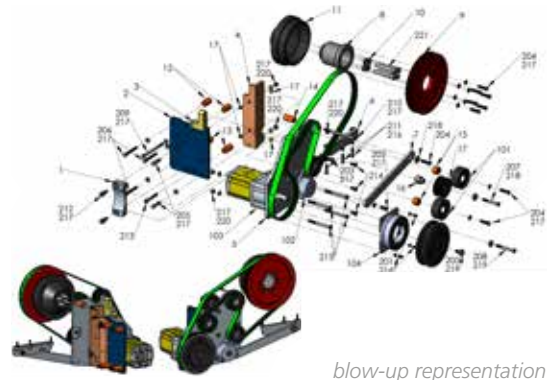

*blow-up representation*

As well as mechanically, fixed-speed generator and compressor solutions, we also provide solutions for variable performance with a hydraulic system catering for single operation or combined when the vehicle motor speed changes to enable variable pump, air and power situations. This way for example, a fireman can vary the distance of his extinguishing water by varying the engine speed and the hydraulic generator ensures that all other electrical components are sufficiently powered.

We also employ this principle in the drain inspection industry where a high pressure pump can be deployed between 0 and 100 % and the vehicle retains its power for other functions. We can connect hydraulic

pumps via a magnetic clutch and additional drive belt (also connectable in the engine compartment) as on the hydraulic snowplough on a winter road clearance vehicle.



*hydraulic hoses*



*From left: hydraulic pump; gear manufacturing; special - motor mounting kit*

### ▪ Applications

- + Control and operation of various aggregates
- + Common in HGVs and construction vehicles

### ▪ Advantages

- + Flexible connection between power source and end function
- + Optimal adaptation based on vehicle characteristics
- + Simple generation of high power and high speeds



*factory floor*

# OUR SERVICE

Martin KFZ-Technik GmbH thanks you for your interest in our system solutions and looks forward to receiving your enquiry.

We welcome you in Nördlingen to see how our products work and show you the many advantages of our products for your purposes.

If you would like a demonstration, please book an appointment with our sales manager Sven Janßen directly by phone: **+49 151 11 45 91 57** or mail him: [sales@kfztechnik-martin.de](mailto:sales@kfztechnik-martin.de)

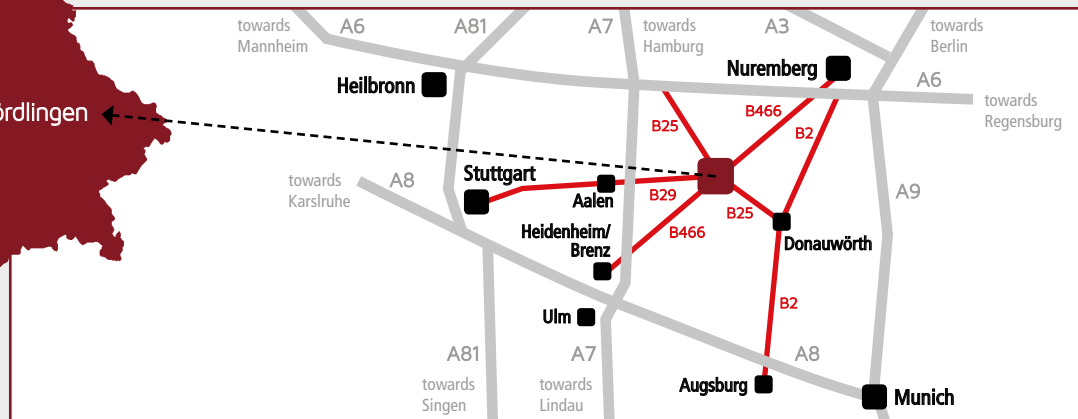
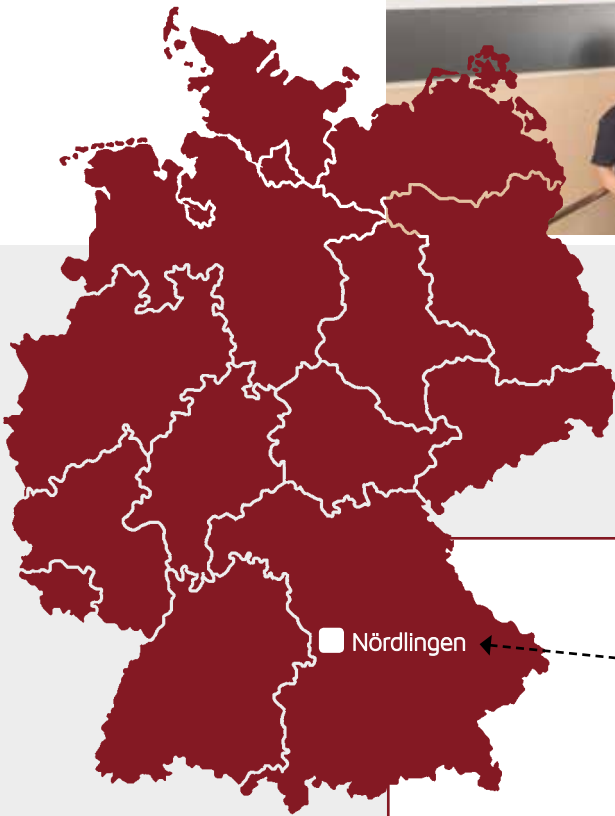

Martin KFZ-Technik GmbH

Fritz-Hopf-Straße 10  
86720 Nördlingen, Germany

Tel.: +49 9081 80 97-0  
Fax: +49 9081 80 97-400

[info@kfztechnik-martin.de](mailto:info@kfztechnik-martin.de)  
[www.kfztechnik-martin.de](http://www.kfztechnik-martin.de)

**Sales-Hotline: +49 151 11 45 91 57**  
[sales@kfztechnik-martin.de](mailto:sales@kfztechnik-martin.de)

Opening times:

Mo. – Th.: 08:00 – 17:00  
Fr.: 08:00 – 13:00