





-  POWER GENERATION
-  COMPRESSED AIR GENERATION
-  AIR CONDITIONING TECHNOLOGY
-  TRANSMISSION SYSTEMS
-  HYDRAULIC SYSTEMS

## Compressed air generation

### Single and combi systems

Space and weight reduction are also the focus in the development of our compressed air systems.

The need for compressed air starts with light applications such as pneumatically operated light masts, compressed air impact wrenches etc. and extends to trenchless hammering, tyre and breakdown service vehicles, up to special vehicles for canal revision or for pipeline construction.

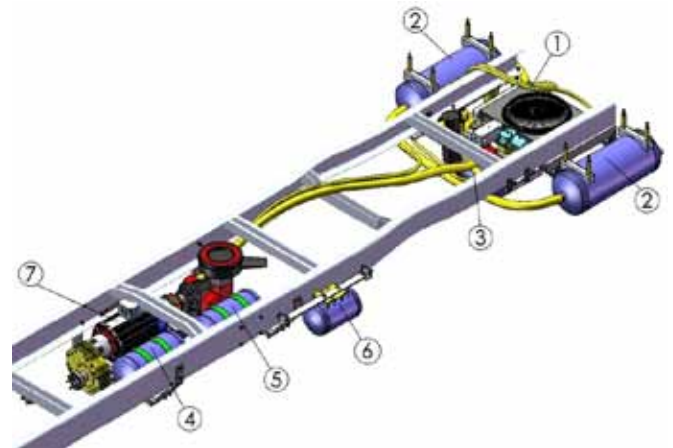

Reductions of several hundred kilos and cubic metres can quickly be achieved in such cases. One of the most expensive components in standard compressors and generators is the motor.

By eliminating this, we are able to reduce the price and maintenance costs significantly, even more so if the generation of electricity and compressed air is combined. Such bespoke special solutions are configured and designed in close consultation with the customer.



## Your advantages

- high payload gain
- more space
- more mobility
- new interior concepts possible
- higher work safety
- operable in low-emission zones



## Suitable vehicle types

Virtually all commercial vehicles that have a suitable gearbox auxiliary drive (PTO), or where this can be retrofitted.

Ask us, we will find the best solution for you!



## Areas of performance

Screw compressors / electr. / 230/400 V / 12 bar/290l/min.  
 Underfloor screw compressors / electr. / 400 V / 12 bar / 1 m<sup>3</sup>/min.  
 Underfloor screw compressors / mech. (PTO) / 12 bar/1.5 – 4.5 m<sup>3</sup>/min.

Special solutions available upon request.



## Application areas

- + all compressed air service applications
- + tyre and breakdown service vehicles
- + construction machinery service
- + trenchless hammering
- + pipeline construction
- + insulation injection
- + mobile hydraulic service
- + truck service vehicles
- + municipal interference suppression vehicles

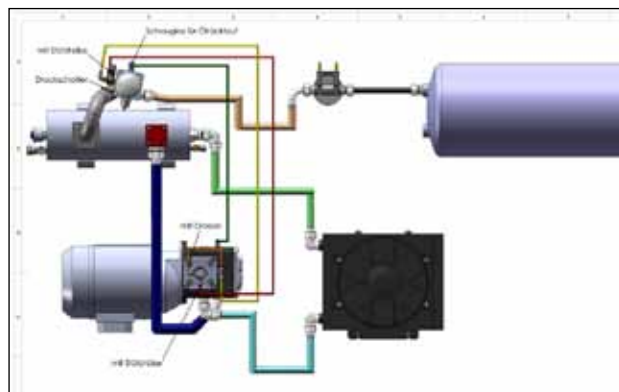

## Contact person

EVTA GROUP  
 Ross Luke  
 0417 125 634  
[rluke@evtagroup.com.au](mailto:rluke@evtagroup.com.au)  
[www.evtagroup.com.au](http://www.evtagroup.com.au)

Individual solutions for the special vehicle sector

With our underfloor systems for generation of electricity and compressed air, you increase your payload and recover loading area. We will happily provide you with further information!

MARTIN KFZ-TECHNIK GmbH  
 Fritz-Hopf-Straße 10 | 86720 Nördlingen  
 Tel. +49 9081 80 97-0 | Fax. +49 9081 8097-400

[info@martin.gmbh](mailto:info@martin.gmbh)  
[www.martin.gmbh](http://www.martin.gmbh)

**MARTIN**  
 KFZ-Technik GmbH